

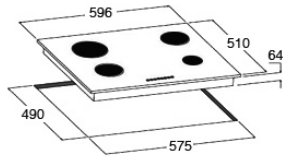

HOBS

Ceramic Hob 60RD 435 Touch

AR. NUMBER
030029501



4 Radiant Ceramic Electric Hob

Dimension: 596x510mm
 Sensor Touch Control Panel
 Outside Tempering Glass
 9 Function
 Safety Lock
 4 Radiant Heating Zone
 Residual Heat Indicator
 Energy Efficiency: Class A
 Power: 150mm/1200W
 150mm/1200W
 180mm/1800W
 150mm/1200W

Ceramic Hob 29RD 232 Touch

AR. NUMBER
030029601

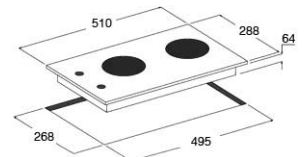

2 Radiant Ceramic Electric Hob

Dimension: 298x510mm
 Sensor Touch Control Panel
 Outside Tempering Glass
 9 Function
 Safety Lock
 2 Radiant Heating Zone
 Residual Heat Indicator
 Energy Efficiency: Class A
 Power: 180mm/1800W
 140mm/1200W

Gas Hob 60KF 458 INOX

AR. NUMBER
030058101

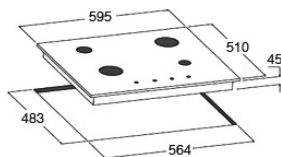

4 Stainless Steel Gas Hob

Dimension: 580x510mm
 Front Control Knob
 Stainless Steel Panel
 Flame Failure Safety Device
 Cast Iron Trivet and Burner Caps
 Under Knob Auto Ignition (Electric/Battery)
 LPG/NG
 1 Rapid Burner 4.3kw
 2 Semi Rapid Burner 1.7kw
 1 Aux Burner 1.0kw

Gas Hob 30KF 223 INOX

AR. NUMBER
030058201

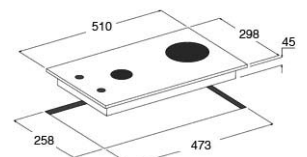

4 Stainless Steel Gas Hob

Dimension: 298x510mm
 Front Control Knob
 Stainless Steel Panel
 Flame Failure Safety Device
 Cast Iron Trivet and Burner Caps
 Under Knob Auto Ignition (Electric/Battery)
 LPG/NG
 1 Rapid Burner 3.0kw
 1 AU Burner 1.0kw

OVENS

Oven 60IN 2110 Inox

AR. NUMBER
034009101

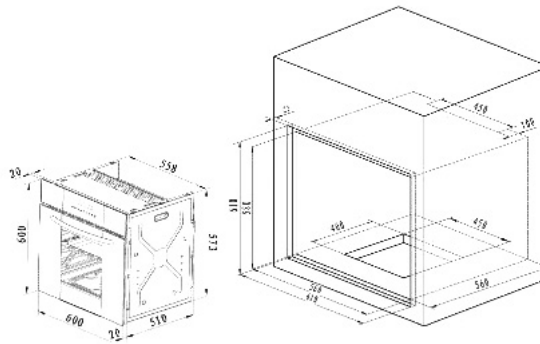

Built-in Electric Oven

Dimensions: 600 x 570 x 600mm
 Net Capacity: 56 litres
 Fully programmable with LED Display
 Cavity Cooling System
 Electronic Clock & Minder Auto off
 Mechanical thermostat (50 - 250°)
 Removal Glass Window and Door
 Cooler to Touch Double Glazed Oven Door
 Accessories: Baking Tray & Shelves

8 Cooking Functions

-  Light
-  Defrost
-  Conventional Cooking
-  Convection
-  Fan Conventional Cooking
-  Dual Circuit Grill
-  Fan Single Circuit Grill
-  Fan Dual Circuit Grill

Energy Efficiency Level: Class A

Power:	
Top Element	800W
Grill Element	1200W
Bottom Element	850W
Rear Element	1300W
Cooling Fan	15W
Convection Fan	25W
Light	15W

Oven 60IN 2140 Inox Gas

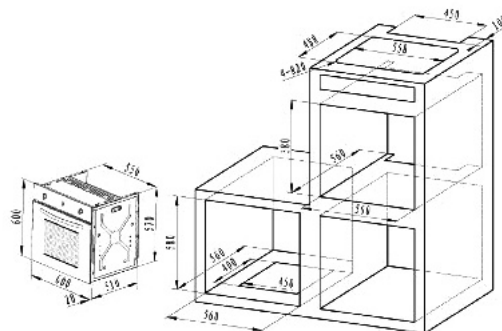

AR. NUMBER
034057201



Built-in Gas Oven

Dimensions: 600 x 570 x 600mm
 Net Capacity: 56 litres
 Cavity Cooling System
 Mechanical Timer 60 minute minder without auto-off
 Mechanical thermostat (50 - 250°)
 Removal Glass Window and Door
 Cooler to Touch Double Glazed Oven Door
 Electronic Auto-Ignition
 Accessories: Baking Tray

3 Cooking Functions

-  Light
-  Gas Oven
-  Rotisserie

Energy Efficiency Level: Class A

Power:	
Top Burner	1300W
Bottom Burner	2300W
Light	15W
Rotisserie	5W

DISHWASHERS

Oven 60IN 2120 Inox

AR. NUMBER
034009201

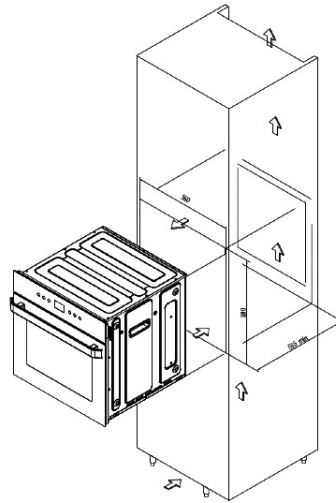

Built-in Electric Oven

Dimensions: 595 x 568 x 596mm
 Net Capacity: 56 litres
 Fully programmable Touch Control Panel
 Cavity Cooling System
 Electronic Clock & Minder with Auto Off
 Mechanical Thermostat (50 - 250°)
 Removal Glass Window & Door
 Cooler to Touch Double Glazed Oven Door
 Electronic Auto Ignition
 Accessories: Baking Tray & Shelves

8 Cooking Functions

- Conventional Cooking
- Convection
- Single Circuit Grill
- Dual Circuit Grill
- Fan Bottom Grill
- Fan Conventional Cooking
- Fan Single Circuit Grill
- Fan Dual Circuit Grill

Oven 60IN 2130 Inox

AR. NUMBER
034009301



Energy Efficiency Level: Class A

Power:

Top Element	950W
Grill Element	2000W
Bottom Element	1100W
Rear Element	2200W
Cooling Fan	20W
Convection Fan	25W
Light	15W

Microwave Oven 28 Inox & Black Glass

AR. NUMBER
034011201

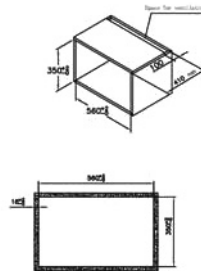

Built-in Microwave Oven

Microwave Dimensions: 305 x 483 x 396mm
 S/S Finishing Frame Dimension: 596x386mm
 Capacity: 25 litres
 S/S Interior Cavity
 Norman Glass
 Timer
 Express Cooking
 Glass Turntable
 Pull Handle Door
 Safety Lock

Digital Control Panel
 Grill Function
 Digital Clock
 Defrost
 Express Cookink
 Preset Function
 End Cooking Signal
 10 Power Level
 900W Power Grill
 1200 Input Power

Microwave Oven 27 Inox

AR. NUMBER
034011101



REFRIGERATORS

Built-in Refrigerator - Freezer CBI 177 No Frost

AR. NUMBER

031001401

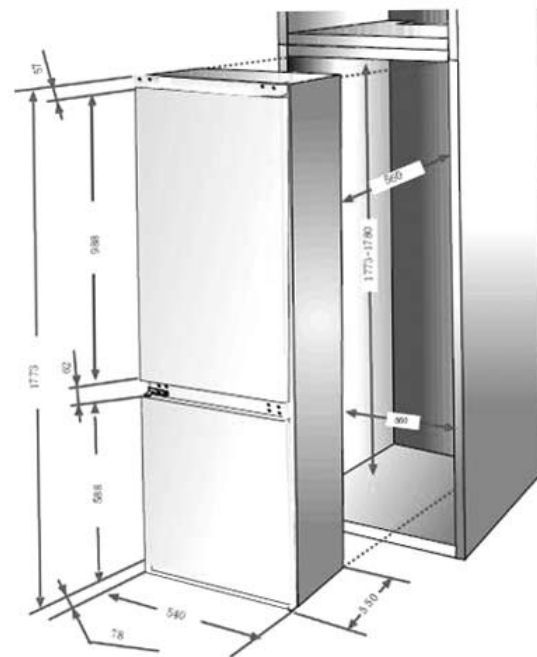

Built-in Refrigerator Freezer

Dimensions: 177 x 54 x 54cm

Capacity: 256 litres
Refrigerator: 183 litres
Freezer: 73 litres

Energy efficiency: Class: A

Basic Features:

- Double Door
- Automatic Defrosting
- 4 Star Rating Freezer
- Noise Level: 42dB
- Adjustable Thermostat
- Grocery Drawer
- 4 Adjustable Tempered Glass Shelves
- Medical Compartment
- Inner Light
- 2 Vegetable Drawer for Freezer
- 3 Drawer Compartment for Freezer

COOKERHOODS

LUME Plus

AR. NUMBER	TYPE
065304101	WALL MOUNTED



inox
black glass

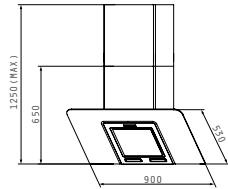

Length: 90cm
Airflow: 1000m³/h
Motor: Turbo Capacitor Motor 160W
3-Speed Motor
Noise Level: 52dB
Buttons: Electronic
Lamps: 2 Led
Stainless Steel Filter: 1

ORIZON Plus

AR. NUMBER	TYPE
065304401	CEILING



inox

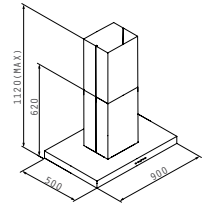

Length: 90cm
Airflow: 1000m³/h
Motor: Turbo Capacitor Motor 160W
3-Speed Motor
Noise Level: 52dB
Buttons: Electronic with remote control
Lamps: 4 Led
Aluminum Cassette Filters: 3

VENTO Plus 90

AR. NUMBER	TYPE
065304201	WALL MOUNTED



inox

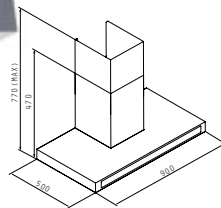

Length: 90cm
Airflow: 1000m³/h
Motor: Turbo Capacitor Motor 160W
3-Speed Motor
Noise Level: 52dB
Buttons: Touch control buttons
Lamps: 2 Led
Aluminum Cassette Filters: 3

VENTO Plus 60

AR. NUMBER	TYPE
065304301	WALL MOUNTED



inox

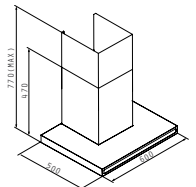

Length: 60cm
Airflow: 850m³/h
Motor: Turbo Capacitor Motor 160W
3-Speed Motor
Noise Level: 52dB
Buttons: Touch control buttons
Lamps: 2 Led
Aluminum Cassette Filters: 2

COOKERHOOD ACCESSORIES

Square Chimney 60

AR. NUMBER	TYPE
065303201	WALL MOUNTED



inox

Length: 60cm
Airflow: 850m³/h
Motor: Turbo Capacitor 160W
3-Speed Motor
Noise Level: 52dB
Buttons: Mechanical Push
Lamps: Electric (2x40W)
 Charcoal Filters Included

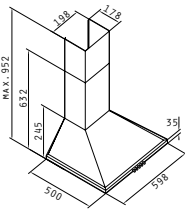

Square Chimney 90

AR. NUMBER	TYPE
065303301	WALL MOUNTED



inox

Length: 90cm
Airflow: 1000m³/h
Motor: Turbo Capacitor Motor 160W
3-Speed Motor
Noise Level: 52dB
Buttons: Mechanical Push
Lamps: Electric (2x40W)
 Charcoal Filters Included

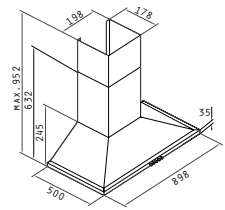

Higher Efficiency, more than double Airflow Capacity for the same consumption of electric power (save energy and money).
 Recovered Overheat Protection Device, cuts off the power to the motor when the motor is overheated, then the device will start the motor when temperature going down.
 Ball Bearing Motor, with 5 years longer life than oil bearing motor.
 Working Stability, less Noise and Shacking.
 Longer Life And Less Maintenance

Standard 60

AR. NUMBER	TYPE
065302501	STANDARD 60CM WHITE 1 MOTOR
065302601	STANDARD 60CM BROWN 1 MOTOR
065302701	STANDARD 60CM INOX 1 MOTOR



white

brown

inox

Length: 60cm
Airflow: 350m³/h
Motor: Turbo Capacitor 160W
3-Speed Motor
Movable Glass
Noise Level: 54dB
Buttons: Mechanical - Push
Lamps: Electric (2x40W)
 Charcoal Filter Included

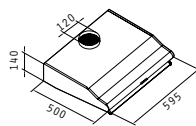

Standard 90

AR. NUMBER	TYPE
065302801	STANDARD COOKER HOOD 90CM WHITE 1 MOTOR
065302901	STANDARD COOKER HOOD 90CM BROWN 1 MOTOR
065303001	STANDARD COOKER HOOD 90CM INOX 1 MOTOR
065303101	STANDARD COOKER HOOD 90CM WHITE 2 MOTORS
065303401	STANDARD COOKER HOOD 90CM BROWN 2 MOTORS



white

brown

inox

Length: 90cm
Airflow: 450³/h
Motor: Turbo Capacitor 160W
3-Speed Motor
Movable Glass
Noise Level: 54dB
Buttons: Mechanical Push
Lamps: Electric (2x40W)
 Charcoal Filter Included

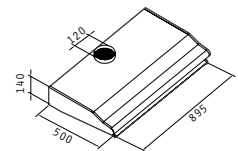

New Turbo Capacitor Motor Feature:

Higher Efficiency, more than double Airflow Capacity for the same consumption of electric power (save energy and money).
 Recovered Overheat Protection Device, cuts off the power to the motor when the motor is overheated, then the device will start the motor when temperature going down.
 Longer Life And Less Maintenance
 Working Stability, less Noise and Shacking.



PYRAMIS U.A.E.

P.O. BOX: 35830, Showroom#2, Al
Fattan Bldg.
Damascus Street, Al Ghusais
Dubai - U.A.E.

Tel.: +971 (0) 4 2632220
Fax: +971 (0) 4 2632225

pyramisuae@emirates.net.ae
www.pyramis.ae

Subsidiary of:

PYRAMIS METALLOURGIA A.E.

17th km Thessaloniki-Serres
P.O. Box 10 278
54110, Thessaloniki
Greece

Tel.: +30 23940 56751
Fax: +30 23940 56745

exportsales@pyramis.gr
www.pyramisgroup.com

